

LRS 36

Light section sensor for object detection

en 07-2014/06 50112362-03

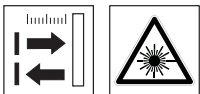

200 ... 800mm

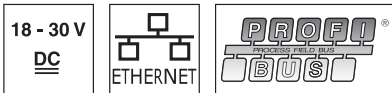

- Light section sensor for object detection
- Response time 10ms
- Detection area: 200 ... 800mm
- Length of laser line: max. 600mm
- Integrated PROFIBUS interface or 4 switching outputs
- Configuration via Fast Ethernet
- OLED display with key pad for alignment aid and status display: "set inspection task"
- Measurement value display in mm on OLED display as an alignment aid
- Up to 16 detection fields with logic operation option
- Up to 16 inspection tasks
- Activation input, trigger input, cascading output
- PROFIBUS connection via Y adapter

We reserve the right to make changes • DS_LRS36_en_50112362_03.fm

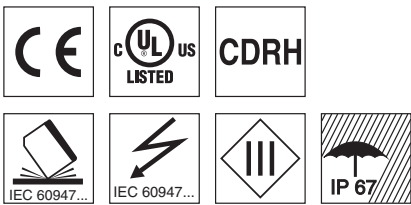

Accessories:

(available separately)

- Mounting systems BT 56, BT 59
- Cable with M12 connector (K-D ...)
- Configuration memory K-DS M12A-8P-0,75m-LxS36-CP

Dimensioned drawing

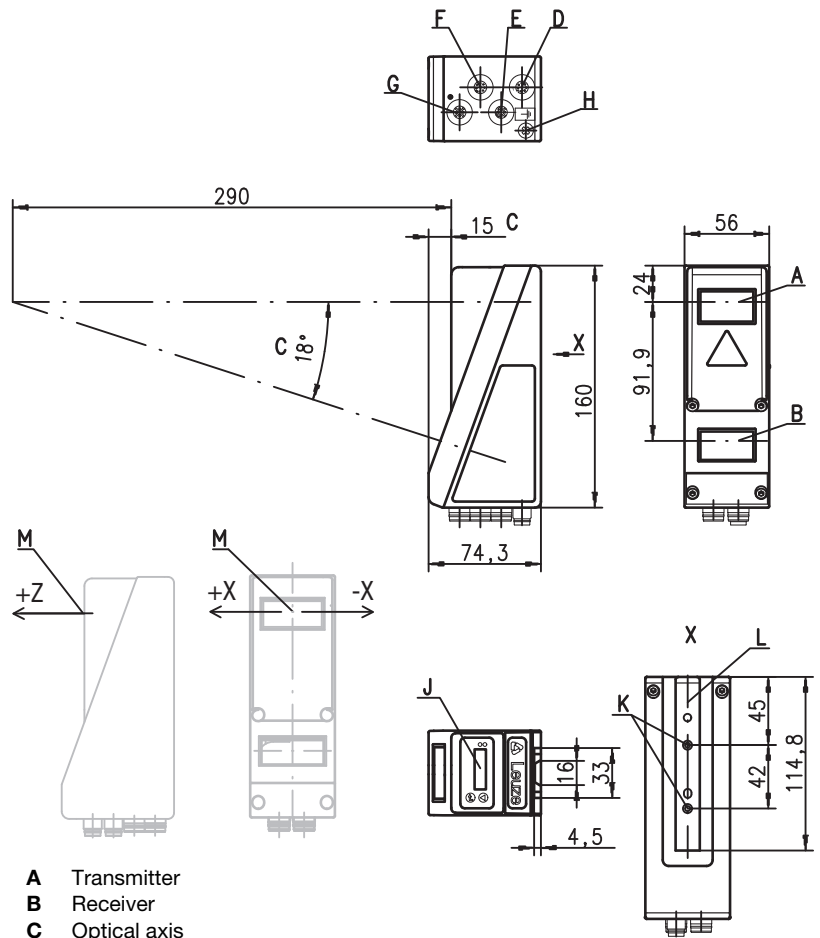

- A Transmitter
- B Receiver
- C Optical axis
- D X1: M12x1 connector, 8-pin, A coded
- E X2: M12x1 socket, 4-pin, D coded
- F X3: M12x1 socket, 8-pin, A coded (only LRS 36/6)
- G X4: M12x1 socket, 5-pin, B coded (only LRS 36/PB)
- H PE screw
- J OLED display and key pad
- K M4 thread, 4.5 deep
- L Holder for mounting system BT 56 / BT 59
- M Zero point and orientation of the coordinate system for measurement data

Detection range, typical

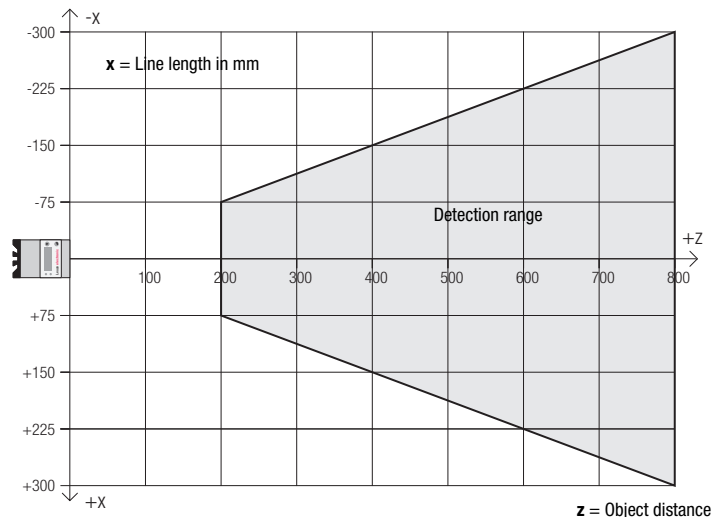

Specifications

Optical data

Detection range ¹⁾	200 ... 800mm (z direction)
Light source	laser
Wavelength	658nm (visible red light)
Max. output power	< 8mW
Pulse duration	3ms
Laser line	600x3mm at 800mm

Object detection

Minimum object size in x direction ²⁾	2 ... 3mm
Minimum object size in z direction ²⁾	2 ... 6mm

Timing

Response time	≥10ms (configurable)
Delay before start-up	approx. 1.5s

Electrical data

Operating voltage U_B ³⁾	18 ... 30VDC (incl. residual ripple)
Residual ripple	≤ 15% of U_B
Open-circuit current	≤ 200mA
Ethernet interface	UDP
Switching outputs	1 (ready) / 100mA / push-pull ⁴⁾ on X1 1 (cascading) / 100mA / push-pull ⁴⁾ on X1 4 / 100mA / push-pull ⁴⁾ ⁵⁾ on X3 (only LRS 36/6)
Inputs	1 (trigger) on X1 1 (activation) on X1 3 (inspection task selection) on X3 (only LRS 36/6) ≥ ($U_B - 2V$) / ≤ 2V
Signal voltage high/low	

PROFIBUS (only LRS 36/PB)

Interface type	1x RS 485 on X4 (only LRS 36/PB)
Protocols	PROFIBUS DP/DPV1 slave
Baud rate	9.6kBaud ... 6MBaud

Indicators

Green LED	continuous light	ready
	off	no voltage
Yellow LED	continuous light	Ethernet connection available
	flashing	Ethernet data transmission active
	off	no Ethernet connection available

Mechanical data

Housing	aluminum frame with plastic cover
Optics cover	glass
Weight	620g
Connection type	M12 connector

Environmental data

Ambient temp. (operation/storage)	-30°C ... +50°C / -30°C ... +70°C
Protective circuit ⁶⁾	1, 2, 3
VDE safety class	III, protective extra-low voltage
Protection class	IP 67
Laser class	2M (according to EN 60825-1 and 21 CFR 1040.10 with Laser Notice No. 50)
Standards applied	IEC/EN 60947-5-2
Certifications	UL 508, C22.2 No.14-13 ³⁾ ⁷⁾

- 1) Luminosity coefficient 6% ... 90%, entire detection range, at 20°C after 30minutes warmup time, medium range U_B
- 2) Minimum value, depends on distance and object, requires testing under application conditions
- 3) For UL applications: for use in class 2 circuits according to NEC only
- 4) The push-pull switching outputs must not be connected in parallel
- 5) Number of detection fields: up to 16 with the option of logic combination
Number of inspection tasks: up to 16 (8 of these can be activated via inputs)
- 6) 1=transient protection, 2=polarity reversal protection, 3=short circuit protection for all outputs, requires external protective circuit for inductive loads
- 7) These sensors shall be used with UL Listed Cable assemblies rated 30V, 0.5A min, in the field installation, or equivalent (categories: CYJV/CYJV7 or PVVA/PVVA7)

Tables

LED	State	Display during measurement operation
green	continuous light	Sensor ready
	off	Sensor not ready
yellow	continuous light	Ethernet connection established
	flashing	Ethernet data transmission active
	off	No Ethernet connection

Diagrams

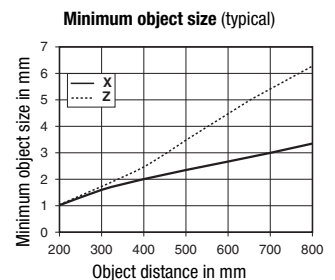
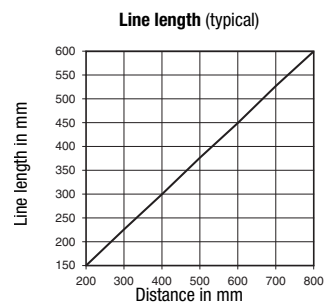

Remarks

Operate in accordance with intended use!

- ⚠ This product is not a safety sensor and is not intended as personnel protection.
- ⚠ The product may only be put into operation by competent persons.
- ⚠ Only use the product in accordance with the intended use.

● Warmup time:

After a warmup time of 30 min., the light section sensor has reached the operating temperature required for an optimum object detection.

Interface assignments

X1 - logic and power		
Pin No.	Signal	Colour
1	+24VDC	WH
2	InAct (activation)	BN
3	GND	GN
4	OutReady (ready)	YE
5	InTrig (trigger)	GY
6	OutCas (cascading)	PK
7	Do not connect	BU
8	Do not connect	RD

8-pin M12 plug, A coded

X2 - Ethernet		
Pin No.	Signal	Colour
1	Tx+	YE
2	Rx+	WH
3	Tx-	OR
4	Rx-	BU

4-pin M12 socket, D coded

X4 - PROFIBUS (only LRS 36/PB)		
Pin No.	Signal	Explanation
1	VP	+5VDC termin.
2	A	RxD/TxD-N, green
3	DGND	Reference potential
4	B	RxD/TxD-P, red
5	FE	Functional earth

5-pin M12 socket, B coded

X3 - logic (only LRS 36/6)		
Pin No.	Signal	Colour
1	Out4	WH
2	Out3	BN
3	GND	GN
4	Out2	YE
5	Out1	GY
6	InSel3 ¹⁾	PK
7	InSel2 ¹⁾	BU
8	InSel1 ¹⁾	RD

8-pin M12 socket, A coded

1) The 3 switching inputs InSel1-3 are used to select the inspection task 0-7. In this context, "000" stands for Inspection Task 0, "001" for Inspection Task 1, etc. The switching time between 2 inspection tasks is < 100ms

Order guide

Part no.	Designation
50111330	LRS 36/6
50111332	LRS 36/PB

Line Range Sensor

with binary inputs/outputs

with PROFIBUS DP/DPV1 (the Y adapter is necessary for connecting the sensor , see accessories)

Laser safety notices



ATTENTION, LASER RADIATION – LASER CLASS 2M

Never look directly into the beam or point the beam in the direction of telescope users!

The device fulfills the EN 60825-1:2008-05 (IEC 60825-1:2007) safety regulations for a product in **laser class 2M** as well as the U.S. 21 CFR 1040.10 regulations with deviations corresponding to "Laser Notice No. 50" from June 24th, 2007.

- ⚠ Never look directly into the laser beam or in the direction of reflecting laser beams!
If you look into the beam path over a longer time period, there is a risk of injury to the retina.
- ⚠ Do not point the laser beam of the device at persons!
- ⚠ Intercept the laser beam with an opaque, non-reflective object if the laser beam is accidentally directed towards a person.
- ⚠ When mounting and aligning the device, avoid reflections of the laser beam off reflective surfaces!
- ⚠ CAUTION! Use of controls or adjustments or performance of procedures other than specified herein may result in hazardous light exposure.
The use of optical instruments or devices (e.g., magnifying glasses, binoculars) with the product will increase eye hazard.
- ⚠ Adhere to the applicable legal and local regulations regarding protection from laser beams acc. to EN 60825 (IEC 60825) in its latest version.
- ⚠ The device must not be tampered with and must not be changed in any way.
There are no user-serviceable parts inside the device.
Repairs must only be performed by Leuze electronic GmbH + Co. KG.

NOTICE

Affix laser information and warning signs!

Laser information and warning signs are affixed to the device (see ①). In addition, self-adhesive laser information and warning signs (stick-on labels) are supplied in several languages (see ②).

- ⚠ Affix the laser information sheet with the language appropriate for the place of use to the device.
When using the device in the US, use the stick-on label with the "Complies with 21 CFR 1040.10" notice.
- ⚠ Affix the laser information and warning signs near the device if no signs are attached to the device (e.g. because the device is too small) or if the attached laser information and warning signs are concealed due to the installation position.
Affix the laser information and warning signs so that they are legible without exposing the reader to the laser radiation of the device or other optical radiation.

①

A Laser exit opening
B Laser warning sign
C Laser information sign with laser parameters

②

50111877-01

<p>LASERSTRAHLUNG NICHT IN DEN STRAHLEN BLICKEN ODER DIREKT MIT OPTISCHEN INSTRUMENTEN BETRACHTEN</p> <p>Max. Leistung (peak): 8,7 mW Impulsdauer: 3 ms Wellenlänge: 658 nm</p> <p>LASERKLASSE 2M DIN EN 60825-1:2008-05</p>	<p>RADIAZIONE LASER NON FISSARE IL FASCIO AD OCCHIO NUDO NE GUARDARE DIRETTAMENTE CON STRUMENTI OTTICI</p> <p>Potenza max. (peak): 8,7 mW Durata dell'impulso: 3 ms Lunghezza d'onda: 658 nm</p> <p>APPARECCHIO LASER DI CLASSE 2M EN 60825-1:2007</p>
<p>LASER RADIATION DO NOT STARE INTO BEAM OR VIEW DIRECTLY WITH OPTICAL INSTRUMENTS</p> <p>Maximum Output (peak): 8,7 mW Pulse duration: 3 ms Wavelength: 658 nm</p> <p>CLASS 2M LASER PRODUCT EN 60825-1:2007</p>	<p>RAYONNEMENT LASER NE PAS REGARDER DANS LE FASCIAU NI A L'ŒIL NU NI A L'ŒIL D'UN INSTRUMENT D'OPTIQUE</p> <p>Puissance max. (crête): 8,7 mW Durée d'impulsion: 3 ms Longueur d'onde: 658 nm</p> <p>APPAREIL A LASER DE CLASSE 2M EN 60825-1:2007</p>
<p>AVOID EXPOSURE – LASER RADIATION IS EMITTED FROM THIS APERTURE</p>	<p>EXPOSITION DANGEREUSE – UN RAYONNEMENT LASER EST ÉMIS PAR CETTE OUVERTURE</p>
<p>RADIACIÓN LASER NO MIRAR FUEJENTE AL HAZ NI MIRAR DIRECTAMENTE CON INSTRUMENTOS ÓPTICOS</p> <p>Potencia máx. (peak): 8,7 mW Duración del impulso: 3 ms Longitud de onda: 658 nm</p> <p>PRODUCTO LASER DE CLASE 2M EN 60825-1:2007</p>	<p>RADIAÇÃO LASER NÃO OLHAR FOCAMENTE O FEIXE NEM OLHAR DIRETAMENTE COM INSTRUMENTOS ÓPTICOS</p> <p>Potência máx. (peak): 8,7 mW Período de pulso: 3 ms Comprimento de onda: 658 nm</p> <p>EQUIPAMENTO LASER CLASSE 2M EN 60825-1:2007</p>
<p>LASER RADIATION DO NOT STARE INTO BEAM OR VIEW DIRECTLY WITH OPTICAL INSTRUMENTS</p> <p>Maximum Output (peak): 8,7 mW Pulse duration: 3 ms Wavelength: 658 nm</p> <p>CLASS 2M LASER PRODUCT EN 60825-1:2007 Complies with 21 CFR 1040.10</p>	<p>激光辐射 勿直视或透过光学 仪器直接观察激光束</p> <p>最大输出 (峰 值) : 8,7 mW 脉冲持续时间: 3 ms 波长: 658 nm</p> <p>2M 类激光产品 GB7247.1-2012</p>

Configuration - Establish connection to PC

The LRS is configured via a PC using the **LRSsoft** program before it is integrated into the process control.

In order to be able to establish an UDP communication with the PC, the IP address of your PC and the IP address of the LRS must lie in the same address range. The LRS has no built-in DHCP client, so that you need to set the address manually. This is done the easiest way via the PC.



Notice!

If you are using a desktop firewall, please ensure that the control can communicate with the LRS via the Ethernet interface on ports 9008 and 5634 using UDP. Furthermore, the firewall must allow ICMP echo messages to pass through for the connection test (ping).

If the PC is usually connected to a network using DHCP address allocation, the easiest way to access the LRS is by applying an alternative configuration in the TCP/IP settings of the PC and connecting the LRS directly to the PC.

☞ Check the network address of the LRS by pressing the **↵** button during normal operation of the LRS twice in succession, then by pressing **▼** twice and followed by pressing the **↵** button again.

This will take you to the **Ethernet** submenu and enable you to read the current settings of the LRS consecutively when pressing **▼** repeatedly.

☞ Make a note of the values for **IP-Address** and **Net Mask Addr.**

The value in **Net Mask Addr.** specifies which digits of the IP address of the PC and LRS must match so that they can communicate with each other.

Address of the LRS	Net mask	Address of the PC
192.168.060.003	255.255.255.0	192.168.060.xxx
192.168.060.003	255.255.0.0	192.168.xxx.xxx

Instead of **xxx** you can now allocate any numbers between 000 and 255 to your PC, but NOT THE SAME numbers as contained in the address of the LRS.

For example 192.168.060.110 (but not 192.168.060.003!). If LRS and PC have the same IP address, they cannot communicate with each other.

Configuring the IP address for a PC

- ☞ Log in to your PC as an administrator.
- ☞ Using **Start->System control** go to the **Network connections** (Windows XP) menu or to the **Network center and release center** (Windows Vista) menu.
- ☞ There select the **LAN connection** and bring up the associated **Features** page by right clicking with the mouse.
- ☞ Select the **Internet protocol (TCP/IP)** (by scrolling down, if necessary) and click on **Properties**.
- ☞ In the **Internet protocol (TCP/IP) Properties** window select the **Alternate configuration** tab.
- ☞ Configure the **IP address** of the PC in the address range of the LRS.
Attention: do not use the same as for the LRS!
- ☞ Set the **Subnet mask** of the PC to the same value as the one for the LRS.
- ☞ Close the configuration dialog by confirming all windows using **OK**.
- ☞ **Connect the interface X2 of the LRS directly to the LAN port of your PC.** Use a **KB ET-...-SA-RJ45** cable for the connection.

The PC will first try to establish a network connection via the automatic configuration. This will take a few seconds. Following that the alternative configuration, which you have just set up, is activated, and thus the PC can communicate with the LRS.

Information about configuring the LRS using **LRSsoft** software can be found in the **Technical Description**.

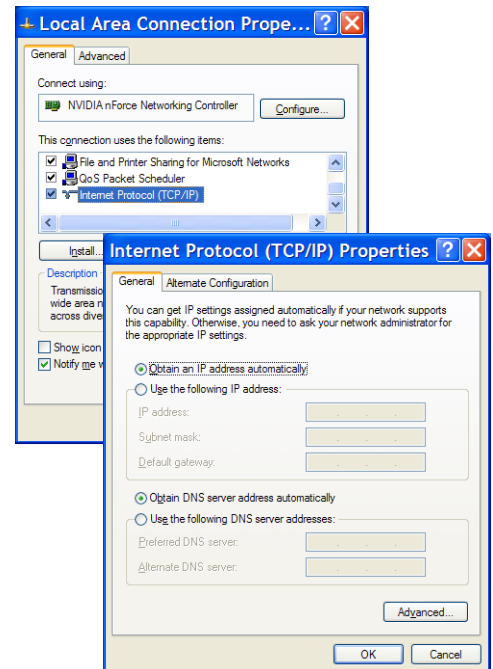

Commissioning



Notice!

The LRS 36/PB PROFIBUS device type is configured as all variants are, via Ethernet through the **LRSsoft** software. LRS 36/PB PROFIBUS device type commissioning notices can be found at the end of this document and in the technical description.

1. Configuring the LRS - see chapter 8 of the Technical Description.
2. Programming process control - see chapter 9 of the Technical Description.
- or
3. Connecting the switching inputs and outputs accordingly - see chapter 6 of the Technical Description.
4. Adapt the IP configuration of the LRS such that it can communicate with the process control. This can be done either via the display of the LRS or in **LRSsoft** in the Configuration area. Here you can change network address and associated net mask as well as the ports via which the LRS communicates with process control.

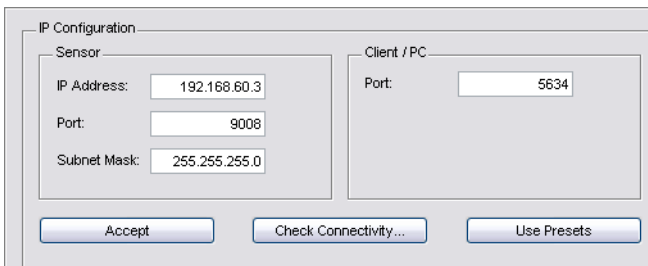

5. Save the changed settings in the LRS using the Configuration->Transmit to sensor command.
6. Connect LRS to process control via the Ethernet interface.
7. Establish connections for activation, triggering and cascading, if necessary.

Installing the configuration software

System requirements

The PC used should meet the following requirements:

- Pentium® or faster Intel® processor > 1.5 GHz (Pentium 4, Celeron, Xeon) or compatible models by AMD® (Athlon 64, Opteron, Sempron). The processor must support the SSE2 instruction set
- At least 512 MB free main memory (RAM), 1024 MB recommended
- CD-ROM drive
- Hard disk with at least 1 GB available memory
- Ethernet port
- Microsoft® Windows XP SP2/3 / Vista SP1 / Windows 7 (32 bit, 64 bit)

Installation procedure



Notice!

If present, *uninstall* Matlab Runtime *before beginning with the installation of the LXSsoft Suite.*

The LXSsoft_Suite_Setup.exe installation program is located on the supplied CD.

LRS 36

Light section sensor for object detection



Notice!

Copy this file from the CD to an appropriate folder on your hard drive.

Administrator rights are necessary for the next steps.

➤ To start the installation process, double-click on file LXSsoft_Suite_Setup.exe.

➤ In the first window, click on Next.

In the next window, you can select whether you would like to install **LRSsoft** only, or **LPSsoft** in addition.

You will need **LPSsoft** in addition, for configuring light section sensors of the LPS series with your PC.

You cannot deselect the first option, **MATLAB Compiler Runtime**, since this component is needed in all cases.

➤ Select the desired options and click on **Next** and, in the next window, click on **Install**.

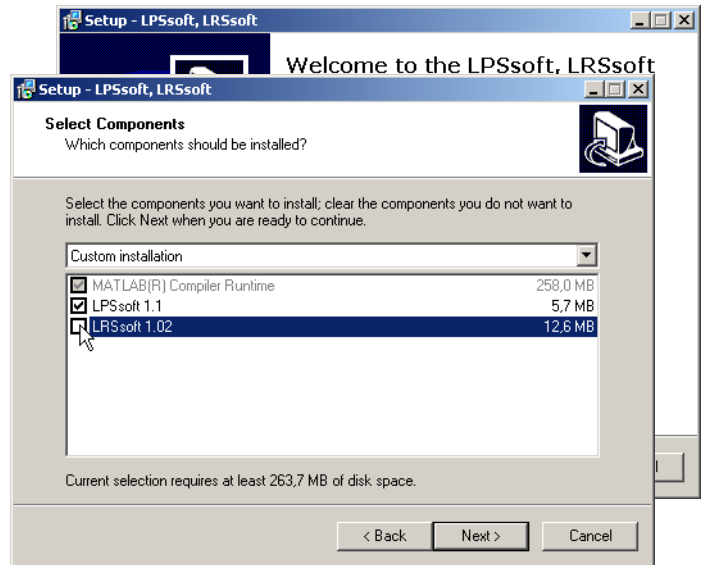

The installation routine starts. After a few seconds, the window for selecting the installation language for the Matlab Compiler Runtime (MCR) appears. The MCR is used for 3D visualization in **LPSsoft**. It is only available in English or Japanese.

➤ Therefore keep in the **Choose Setup Language** window the selection **English** and click on **OK**.

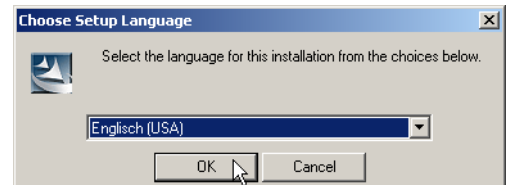

Depending on the configuration of your Windows system the adjacent dialog can also appear (missing component VCREDIST_X86).

➤ Click on **Install**.

Two additional installation windows will appear, which do not require any further entry.

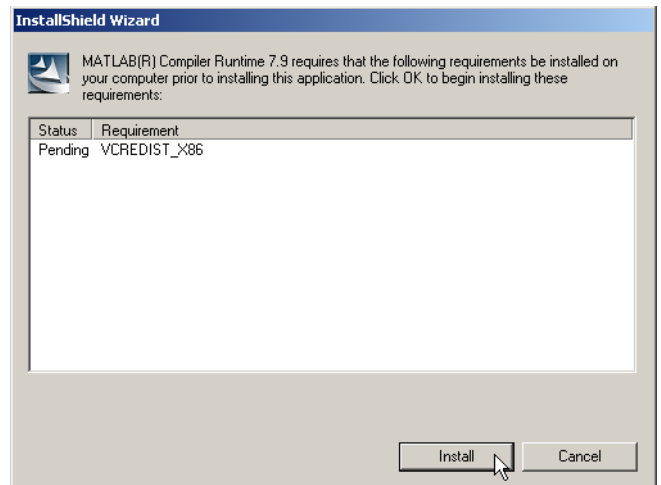

After some time (up to several minutes depending on the system configuration) the start screen of the MCR installer will appear.

☞ Click on **Next**.

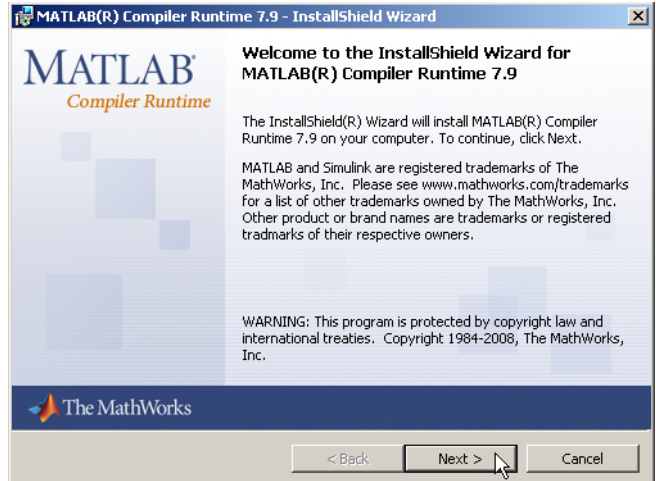

The window for entering user data appears.

☞ Enter your name and the company name and then click on **Next**.

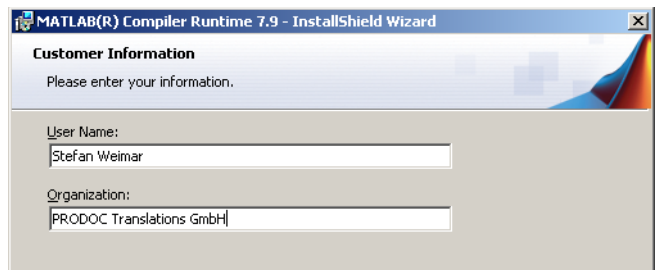

☞ It is essential that you retain the default folder in the window for the selection of the installation path (Destination Folder).

The standard path is

C:\Programs\MATLAB\MATLAB Compiler Runtime\.

☞ Click on **Next** and in the next window click on **Install**.

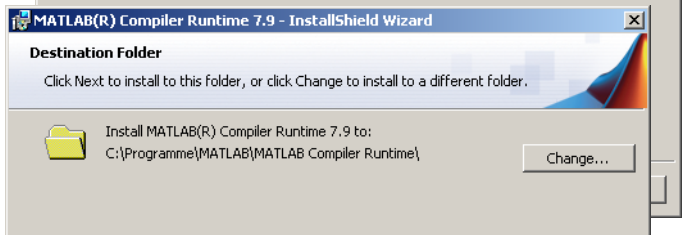

The installation will start and the adjacent status window will be displayed. This can again take several minutes.

Following successful MCR installation, the InstallShield Wizard Completed window appears.

☞ Click on **Finish** to end the MCR-installation.

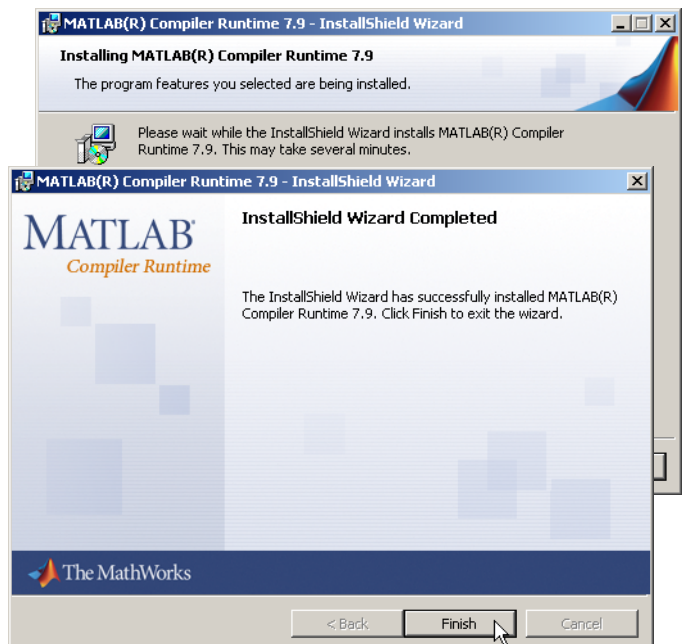

LRS 36

Light section sensor for object detection

The window for selecting the installation path for **LRSsoft** now appears.

☞ Keep the default folder and click on **Next**.

The installation of **LRSsoft** starts. If you also selected **LPSsoft** for installation, upon completion of the **LRSsoft** installation, the same window then reappears for entering the installation path for **LPSsoft**.

☞ Keep the default folder in this case as well and click on **Next**.

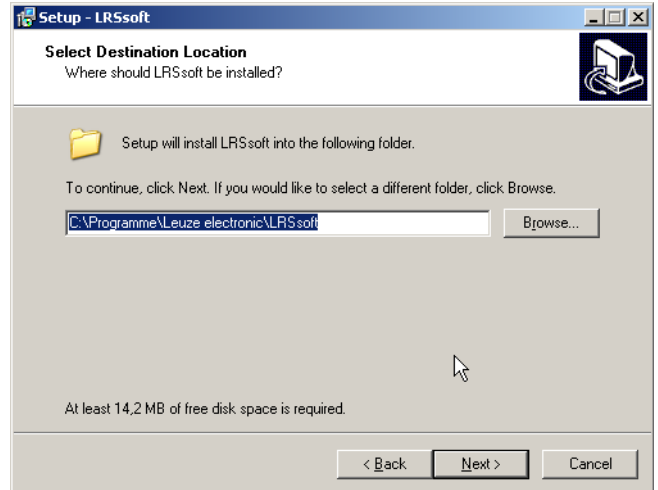

Upon completion of the installation process, the adjacent window appears.

The installation routine added a new **Leuze electronic** program group in your Start menu that contains the installed programs **LRSsoft** and, if selected, **LPSsoft**.

☞ Click on **Finish** and then start the desired program from the Start menu.

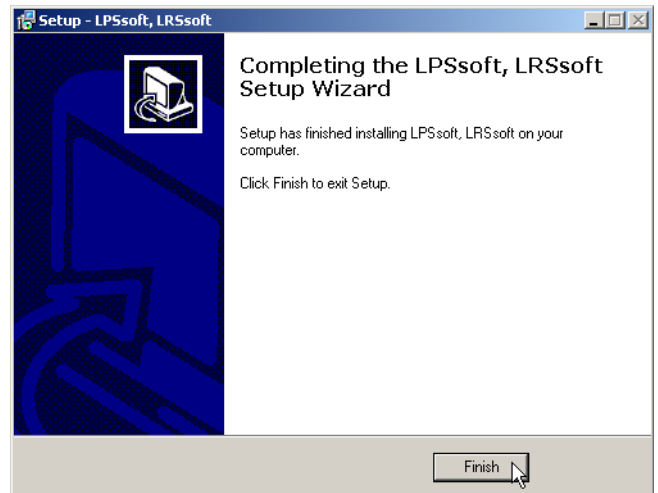

Possible error message

Depending on the system configuration the adjacent error message can appear at this point. The cause of this error message is a bug in the MCR installation routine, which does not set the environment variable `Path` correctly in some systems.



That, however, can easily be corrected without reinstallation of the MCR.

➤ Open the System properties window located in the System control of Windows under System.

➤ Go to the Advanced tab and click on Environment variables.

The Environment variables window opens.

➤ Scroll down in the System variables area until you find the Path entry.

➤ Click on Path and then on Edit.

The Edit system variable window opens.

There in the Variable value field you will find the `;C:\Programs\MATLAB\MATLAB Compiler Runtime\v79\runtime\win32` entry right at the end.

➤ If this entry is missing, copy the entry from this document and insert it together with the preceding semicolon.

➤ Then click on OK and close also all further windows using OK.

➤ Shut Windows down, restart Windows and then start **LRSsoft** by double-clicking on it.

Now the start screen of **LRSsoft** appears, as described in chapter 8 of the LRS technical description.

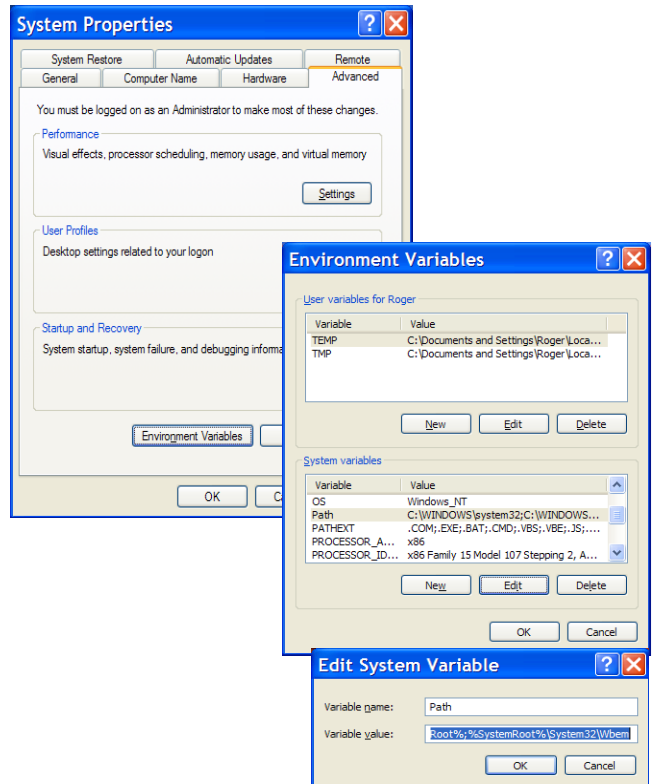

LRS 36/PB PROFIBUS device type

General Information - Technical characteristics

The sensor is configured as all device variants are, via the **LRSsoft** configuration software.

The LRS 36/PB is designed as a PROFIBUS DP/DPV1 compatible slave. The input/output functionality of the sensor is defined by the corresponding GSD file. The baud rate of the data to be transmitted is max. 6MBit/s under production conditions.

Setting of the PROFIBUS address:

The LRS 36/PB supports the automatic detection of the baud rate and the automatic address assignment via the PROFIBUS. Alternatively, the PROFIBUS address can be set via the display and key pad or via the **LRSsoft** configuration software.

PROFIBUS connection

Connection to the PROFIBUS is done via the **X4** 5-pin M12 socket with an **external Y plug adapter**. The assignment corresponds to the PROFIBUS standard. The Y plug adapter makes possible the exchange of the LRS 36/PB without interrupting the PROFIBUS cable. The external Y plug adapter is also needed when the LRS 36/PB is the last network device. Then the external bus terminating resistor (termination) is connected to it. The 5V supply of the active termination is applied to **X4** (pin 1). **This is then further looped only via the outgoing side** of the Y plug adapter.

Simultaneous operation on Ethernet and PROFIBUS

- Ethernet and PROFIBUS can be used in measure mode as fully-fledged interfaces.
- If the sensor is configured with **LRSsoft** and simultaneously operated on PROFIBUS, queries from the control are processed and the process data is updated with a delay (indicated by slowly increasing scan numbers). Process data is updated every 200ms.
During configuration of the LRS 36/PB with **LRSsoft**, it must be determined whether the PROFIBUS or **LRSsoft** may perform the changeover of the inspection task. This is set with the **Enable external inspection task selection** checkbox.



Notice!

*When **LRSsoft** has established a connection to LRS 36/PB, the software switches the sensor into configuration mode. The update rate is max. 5Hz. If the sensor is in free running mode, the flashing of the laser beam indicates this.*

- If the sensor is in menu mode or command mode, communication via PROFIBUS is possible.
Queries from the control are not processed and the process data is frozen (indicated by the constant scan number).

General information about the GSD file

The functionality of sensor inputs/outputs for the control is defined via a module. The necessary module is integrated via a user-specific configuration tool during PLC program creation and configured corresponding to the application.

The short form of the module description is included in this data sheet. Please refer to the technical documentation for the detailed description.



Notice!

A module from the GSD file must be activated in the configuration tool of the control, usually module M1 or M2.

Parameters can be changed via the display for test purposes on a LRS 36/PB operating on the PROFIBUS. At this time, object detection on PROFIBUS is not possible.



Notice!

*All input and output modules described in the documentation are described **from the viewpoint of the control**:*

Inputs (I) described are inputs of the control.

Outputs (O) described are outputs of the control.

Parameters (P) described are parameters of the GSD file in the control.

The LRS 36/PB has a module slot. With the selection of the corresponding module from the GSD, the process data of the LRS 36/PB to be transmitted is set. A selection of several modules is available. Beginning with **M1**, the simplest input module, new inputs are added to subsequent modules. All available output data is already included in module **M1**. The modules with higher numbers each contain the modules with lower numbers (example: **M2** contains **M1** and the extensions of **M2**).



Notice!

As the module number increases, so do the user data bytes to be transmitted.

*The maximal measurement rate of 100Hz can only be guaranteed up to module **M3**.*

Therefore, only modules which contain the data actually required should be selected, i.e. the smallest possible module number should be selected.

LRS 36

Light section sensor for object detection

Overview of the modules in the GSD file

Output data (from viewing position of control)

Position	Name	Bits in byte								Value range	Meaning
		Bit7	Bit6	Bit5	Bit4	Bit3	Bit2	Bit1	Bit0		
0	uTrigger	Trig_7	Trig_6	Trig_5	Trig_4	Trig_3	Trig_2	Trig_1	Trig_0	0 ... 255	Triggering via PROFIBUS (in the case of changes)
1	uActivation	-	-	-	-	-	-	-	Act_0n	0 ... 1	Activation (=1) or deactivation (=0) of the sensor
2	uInspTask	-	-	-	-	IT_b3	IT_b2	IT_b1	IT_b0	0 ... 15	Inspection task of PROFIBUS master and save flag (B7)

Input data (from viewing position of control)

GSE Module	Position (bytes)	Name	Bits in byte								Value range	Meaning
			Bit7	Bit6	Bit5	Bit4	Bit3	Bit2	Bit1	Bit0		
M1 4 byte	0	wScanNum (HighByte)	SN_b15	SN_b14	SN_b13	SN_b12	SN_b11	SN_b10	SN_b9	SN_b8	0 ... 255	Scan number (Highbyte)
	1	wScanNum (LowByte)	SN_b7	SN_b6	SN_b5	SN_b4	SN_b3	SN_b2	SN_b1	SN_b0	0 ... 255	Scan number (Lowbyte)
	2	uSensorInfo	Out4	Out3	Out2	Out1	IT_b3	IT_b2	IT_b1	IT_b0	0 ... 255	SensorInfo (inspection task no., output state)
	3	uSensorState	ErrM	Cmd	Menu	Meas	ErrF	WarnF	active	connect	0 ... 255	Sensor state
M2 6 byte	4	wResultAWs (HighByte)	AW16	AW15	AW14	AW13	AW12	AW11	AW10	AW9	0 ... 255	State of AWs (Highbyte)
	5	wResultAWs (LowByte)	AW8	AW7	AW6	AW5	AW4	AW3	AW2	AW1	0 ... 255	State of AWs (Lowbyte)
M3 16 byte	6	wActObjPtsAW1 (HighByte)	-	-	-	-	-	-	-	OP_b8	0 ... 1	Current number of hit points in analysis window 1
	7	wActObjPtsAW1 (LowByte)	OP_b7	OP_b6	OP_b5	OP_b4	OP_b3	OP_b2	OP_b1	OP_b0	0 ... 255	
	8	wActObjPtsAW2 (HighByte)	-	-	-	-	-	-	-	OP_b8	0 ... 1	Current number of hit points in analysis window 2
	9	wActObjPtsAW2 (LowByte)	OP_b7	OP_b6	OP_b5	OP_b4	OP_b3	OP_b2	OP_b1	OP_b0	0 ... 255	
	10	wActObjPtsAW3 (HighByte)	-	-	-	-	-	-	-	OP_b8	0 ... 1	Current number of hit points in analysis window 3
	11	wActObjPtsAW3 (LowByte)	OP_b7	OP_b6	OP_b5	OP_b4	OP_b3	OP_b2	OP_b1	OP_b0	0 ... 255	
	12	wActObjPtsAW4 (HighByte)	-	-	-	-	-	-	-	OP_b8	0 ... 1	Current number of hit points in analysis window 4
	13	wActObjPtsAW4 (LowByte)	OP_b7	OP_b6	OP_b5	OP_b4	OP_b3	OP_b2	OP_b1	OP_b0	0 ... 255	
M4 24 byte	14	wActObjPtsAW5 (HighByte)	-	-	-	-	-	-	-	OP_b8	0 ... 1	Current number of hit points in analysis window 5
	15	wActObjPtsAW5 (LowByte)	OP_b7	OP_b6	OP_b5	OP_b4	OP_b3	OP_b2	OP_b1	OP_b0	0 ... 255	
	16	wActObjPtsAW6 (HighByte)	-	-	-	-	-	-	-	OP_b8	0 ... 1	Current number of hit points in analysis window 6
	17	wActObjPtsAW6 (LowByte)	OP_b7	OP_b6	OP_b5	OP_b4	OP_b3	OP_b2	OP_b1	OP_b0	0 ... 255	
	18	wActObjPtsAW7 (HighByte)	-	-	-	-	-	-	-	OP_b8	0 ... 1	Current number of hit points in analysis window 7
	19	wActObjPtsAW7 (LowByte)	OP_b7	OP_b6	OP_b5	OP_b4	OP_b3	OP_b2	OP_b1	OP_b0	0 ... 255	
	20	wActObjPtsAW8 (HighByte)	-	-	-	-	-	-	-	OP_b8	0 ... 1	Current number of hit points in analysis window 8
	21	wActObjPtsAW8 (LowByte)	OP_b7	OP_b6	OP_b5	OP_b4	OP_b3	OP_b2	OP_b1	OP_b0	0 ... 255	
22	wActObjPtsAW9 (HighByte)	-	-	-	-	-	-	-	OP_b8	0 ... 1	Current number of hit points in analysis window 9	
23	wActObjPtsAW9 (LowByte)	OP_b7	OP_b6	OP_b5	OP_b4	OP_b3	OP_b2	OP_b1	OP_b0	0 ... 255		
M5 38 byte	24	wActObjPtsAW10 (HighByte)	-	-	-	-	-	-	-	OP_b8	0 ... 1	Current number of hit points in analysis window 10
	25	wActObjPtsAW10 (LowByte)	OP_b7	OP_b6	OP_b5	OP_b4	OP_b3	OP_b2	OP_b1	OP_b0	0 ... 255	
	26	wActObjPtsAW11 (HighByte)	-	-	-	-	-	-	-	OP_b8	0 ... 1	Current number of hit points in analysis window 11
	27	wActObjPtsAW11 (LowByte)	OP_b7	OP_b6	OP_b5	OP_b4	OP_b3	OP_b2	OP_b1	OP_b0	0 ... 255	
	28	wActObjPtsAW12 (HighByte)	-	-	-	-	-	-	-	OP_b8	0 ... 1	Current number of hit points in analysis window 12
	29	wActObjPtsAW12 (LowByte)	OP_b7	OP_b6	OP_b5	OP_b4	OP_b3	OP_b2	OP_b1	OP_b0	0 ... 255	
	30	wActObjPtsAW13 (HighByte)	-	-	-	-	-	-	-	OP_b8	0 ... 1	Current number of hit points in analysis window 13
	31	wActObjPtsAW13 (LowByte)	OP_b7	OP_b6	OP_b5	OP_b4	OP_b3	OP_b2	OP_b1	OP_b0	0 ... 255	
	32	wActObjPtsAW14 (HighByte)	-	-	-	-	-	-	-	OP_b8	0 ... 1	Current number of hit points in analysis window 14
	33	wActObjPtsAW14 (LowByte)	OP_b7	OP_b6	OP_b5	OP_b4	OP_b3	OP_b2	OP_b1	OP_b0	0 ... 255	
	34	wActObjPtsAW15 (HighByte)	-	-	-	-	-	-	-	OP_b8	0 ... 1	Current number of hit points in analysis window 15
	35	wActObjPtsAW15 (LowByte)	OP_b7	OP_b6	OP_b5	OP_b4	OP_b3	OP_b2	OP_b1	OP_b0	0 ... 255	
	36	wActObjPtsAW16 (HighByte)	-	-	-	-	-	-	-	OP_b8	0 ... 1	Current number of hit points in analysis window 16
	37	wActObjPtsAW16 (LowByte)	OP_b7	OP_b6	OP_b5	OP_b4	OP_b3	OP_b2	OP_b1	OP_b0	0 ... 255	

You can find detailed information in the technical description of the LRS 36.

PROFIBUS accessories

Ready-made cables with M12 connector and open end

M12 socket
(B coded)

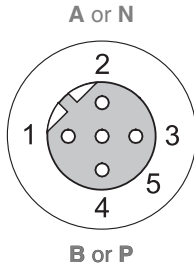

M12 connector
(B coded)

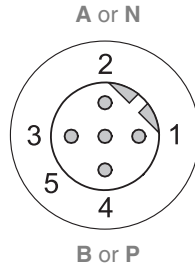

Contact	Signal	Colour
M12 connector M12 socket		
1	n.c.	
2	A / N	green
3	n.c.	
4	B / P	red
5	n.c.	
Screw connection	Shield	bright

Part no.	Type designation	Description
50104181	KB PB-2000-BA	M12 socket for BUS IN, axial connector, open cable end, cable length 2m
50104180	KB PB-5000-BA	M12 socket for BUS IN, axial connector, open cable end, cable length 5m
50104179	KB PB-10000-BA	M12 socket for BUS IN, axial connector, open cable end, cable length 10m
50104188	KB PB-2000-SA	M12 connector for BUS OUT, axial connector, open cable end, cable length 2m
50104187	KB PB-5000-SA	M12 connector for BUS OUT, axial connector, open cable end, cable length 5m
50104186	KB PB-10000-SA	M12 connector for BUS OUT, axial connector, open cable end, cable length 10m
50104097	KB PB-2000-SBA	M12 connector + M12 socket for Profibus, axial connector, cable length 2m
50104098	KB PB-5000-SBA	M12 connector + M12 socket for Profibus, axial connector, cable length 5m
50104099	KB PB-10000-SBA	M12 connector + M12 socket for Profibus, axial connector, cable length 10m

PROFIBUS terminating resistor

Part no.	Type designation	Description
50038539	TS 02-4-SA M12	M12 connector with integrated terminating resistor for BUS OUT

PROFIBUS Y plug adapter

Part no.	Type designation	Description
50109834	KDS BUS OUT M12-T-5P	M12 T-connector for BUS OUT

PROFIBUS GSD file



Notice!

The current version of the GSD file **LEUZE401.GSD** for the LRS 36/PB can be found on the Leuze website www.leuze.com.